

NOVEMBRE 2011

LED OSRAM 12v

BackLED S – BA01SA

Product	Color	Price	No. of LED-modules per chain	No. of LEDs per module	Power module W	Radiance Angle (°)	Wavelength (nm) Color Temp (K)	Lum.Flux module (lm)
BA01SA-W4F-765	White	€198,00	90	1	0.17	155	6500 K	14.9
BA01SA-W4F-830	White	€198,00	90	1	0.17	155	3000 K	12.6
BA01SA-R2	Red	€159,00	90	1	0.17	155	625 nm	4.8
BA01SA-O2	Orange	€189,00	90	1	0.17	155	603 nm	5.7
BA01SA-G2	Green	€219,00	90	1	0.17	155	522 nm	6.1
BA01SA-B2	Blue	€219,00	90	1	0.17	155	467 nm	1.8

BackLED M – BA01MA

Product	Color	Price	No. of LED-modules per chain	No. of LEDs per module	Power module W	Radiance Angle (°)	Wavelength (nm) Color Temp (K)	Lum.Flux module (lm)
BA01MA-W4F-765	White	€ 255,00	60	1	0.5	155	6500 K	31.1
BA01MA-W4F-830	White	€ 255,00	60	1	0.5	155	3000 K	23.1
BA01MA-R2	Red	€ 255,00	60	1	0.5	155	623 nm	16.2
BA01MA-O2	Blue	€ 282,00	60	1	0.5	155	468 nm	6.9

BackLED L – BA01LA

Product	Color	Price	No. of LED-modules per chain	No. of LEDs per module	Power module W	Radiance Angle (°)	Wavelength (nm) Color Temp (K)	Lum.Flux module (lm)
BA01LA-W4F-765	White	€ 594,00	48	1	1.25	155	6500 K	97.5
BA01LA-W4F-830	White	€ 594,00	48	1	1.25	155	3000 K	75.0

BoxLED Back – BX03BA

Product	Color	Price	No. of LED-modules per chain	No. of LEDs per module	Power module W	Radiance Angle (°)	Wavelength (nm) Color Temp (K)	Lum.Flux module (lm)
BX03BA-W4F-765	White	€ 594,00	16	3	3.75	155	6500 K	292.5

BoxLED Side – BX03SA

Product	Color	Price	No. of LED-modules per chain	No. of LEDs per module	Power module W	Radiance Angle (°)	Wavelength (nm) Color Temp (K)	Lum.Flux module (lm)
BX03SA-W4F-765	White	€ 495,00	8	3	7.50	12X65	6500 K	491.5

Alimentatori

OTe15/220-240/12P	15 W	€ 39,00
OTe30/220-240/12P	30 W	€ 57,00
OTe60/220-240/12P	60 W	€ 79,50
OTe120/220-240/12P	120W	€ 109,50

BackLED S – BA01SA



Benefits

- Flexible chain comprising 90 LED modules
- Specially designed optics provide for uniform backlighting and best-in-class application efficiency

Applications

- Signage and illuminated advertising
- Backlighting of small and flat channel letters

Technical Operating Data

Product	Color	No. of LED-modules per chain	No. of LEDs per module	Voltage [V DC]*	Power chain / module [W]*	Radiance Angle [°]*	Wavelength [nm] Color Temp [K]*	Lum. Flux chain / module [lm]*
BA01SA-W4F-765	White	90	1	12	15.0 / 0.17	155	6500 K	1341 / 14.9
BA01SA-W4F-830	White	90	1	12	15.0 / 0.17	155	3000 K	1134 / 12.6
BA01SA-R2	Red	90	1	12	15.0 / 0.17	155	625 nm	432 / 4.8
BA01SA-O2	Orange	90	1	12	15.0 / 0.17	155	603 nm	513 / 5.7
BA01SA-G2	Green	90	1	12	15.0 / 0.17	155	522 nm	549 / 6.1
BA01SA-B2	blue	90	1	12	15.0 / 0.17	155	467 nm	162 / 1.8

*) Due to the special conditions of the manufacturing processes of LED the typical data of technical parameters can only reflect statistical figures and do not necessarily correspond to the actual parameters of each single product which could differ from the typical data.

Technical Features

- LED chain comprising 90 LED modules connected by flexible cables
- The maximum length of the entire chain is 7.20m
- The maximum LED pitch is 80mm
- Specially designed optics with Flat-Ray technology for best application efficiency
- One LED per module
- Mounting holes and pre-mounted adhesive tape allow for easy mounting
- Optimal operation on OPTOTRONIC® 12V power supplies (15W, 30W, 60W, 120W)
- Full encapsulation of the LED modules with ingress protection IP66
- Chain can be subdivided every 3 LED modules

Minimum / Maximum Ratings

Product	Operating Temperature at Tc-Point [°C]*	Storage Temperature [°C]*	Voltage Range [V dc]*	Reverse Voltage [V dc]*
BA01SA-W4F-765	-25 ... 78	-25 ... 55	12 ... 13	13
BA01SA-W4F-830	-25 ... 78	-25 ... 55	12 ... 13	13
BA01SA-R2	-25 ... 78	-25 ... 55	12 ... 13	13
BA01SA-O2	-25 ... 78	-25 ... 55	12 ... 13	13
BA01SA-G2	-25 ... 78	-25 ... 55	12 ... 13	13
BA01SA-B2	-25 ... 78	-25 ... 55	12 ... 13	13

*) Exceeding maximum ratings for operating and storage temperature will reduce expected life time or destroy the LED Modules.
 Exceeding maximum ratings for operating voltage will cause hazardous overload and will likely destroy the LED Modules.
 The temperature of the LED modules must be measured at the Tc-point according to EN60598-1 in a thermally constant status with a temperature sensor or a temperature sensitive label.

Dimensions

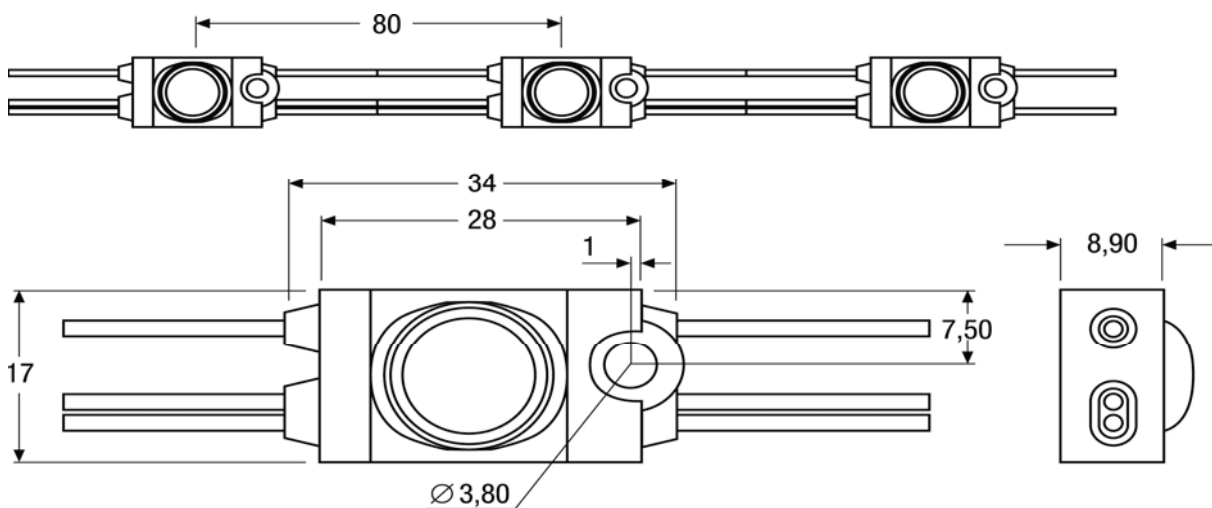

Light Distribution

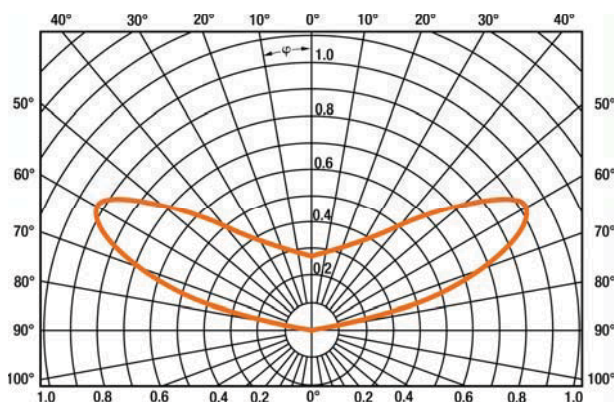

Safety Information

- The LED module itself and all its components must not be mechanically stressed.
- Assembly must not damage or destroy conducting paths on the circuit board.
- To avoid mechanical damage, the LED modules should be attached securely to the intended substrate. Heavy vibration should be avoided.

In order to drive OSRAM LED-Modules safely, it is absolutely necessary to operate them with an electronically stabilized power supply protecting against short circuits, overload and overheating.

To also ease the luminaire/installation approval, electronic control gear for LED or LED modules must carry the CE mark.

In Europe the declarations of conformity must include the following standards:

CE: EC 61347-2-13, EN 55015, IEC 61547 and IEC 61000-3-2 - ENEC: 61347-2-13 and IEC/EN 62384.

Also check for the mark of an independent authorized certification institute.

Please see the relevant brochure for more detailed information (see "Related and Further Information")

OSRAM OPTOTRONIC® electronic control gear complies to all relevant standards and guarantees safe operation.

- Installation of LED modules (with power supplies) needs to be made with regard to all applicable electrical and safety standards. Only qualified personnel should be allowed to perform installations.
- Observe correct polarity!
Incorrect polarity will lead to no light emission. Correct polarity.
- Parallel connection is highly recommended as safe electrical operation mode.
Serial connection is not recommended. Unbalanced voltage drop can cause hazardous overload and damage the LED module.
- Electrical contact is achieved with the contact cables. A maximum 90 modules (30 groups with 3 modules each) can be operated on one OPTOTRONIC® 15W
- Installation with more than 90 modules (= one full chain) on one OPTOTRONIC® 30W, 60W or 120W may take the form with a power feed to the centre or with a splitting of the power feed to contact groups of single LED modules.
- Detach the chains only by severing the connecting cables between the modules. Only cut where there are 2 cables leaving the LED module. Not to be cut where 3 cables leave the LED module.
- Pay attention to ESD steps when mounting the module.
- When using power supplies other than OSRAM OPTOTRONIC®, in order to ensure continuous safe operation, the output voltage has to be 12.5V +/- max. 5%.
- The LED module must not be operated in places which are directly exposed to atmospheric conditions. For outdoor applications, hence the LED module has to be protected by appropriate enclosures or covers. Operation in or under water is prohibited.

BackLED M – BA01MA

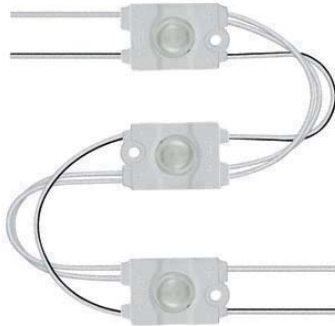

Benefits

- Flexible chain comprising 60 medium power LED modules
- Specially designed optics provide for uniform backlighting and best-in-class application efficiency

Applications

- Signage and illuminated advertising
- Backlighting of medium-sized channel letters

Technical Operating Data

Product	Color	No. of LED-modules per chain	No. of LEDs per module	Voltage [V DC]*	Power chain / module [W]*	Radiance Angle [°]*	Wavelength [nm] Color Temp [K]*	Lum. Flux chain / module [lm]*
BA01MA-W4F-765	White	60	1	12	30.0 / 0.5	155	6500 K	1866 / 31.1
BA01MA-W4F-830	White	60	1	12	30.0 / 0.5	155	3000 K	1386 / 23.1
BA01MA-R2	Red	60	1	12	30.0 / 0.5	155	623 nm	972 / 16.2
BA01MA-B2	blue	60	1	12	30.0 / 0.5	155	468 nm	414 / 6.9

*) Due to the special conditions of the manufacturing processes of LED the typical data of technical parameters can only reflect statistical figures and do not necessarily correspond to the actual parameters of each single product which could differ from the typical data.

Technical Features

- LED chain comprising 60 LED modules connected by flexible cables
- The maximum length of the entire chain is 7.20m
- The maximum LED pitch is 120mm
- Specially designed optics with Flat-Ray technology for best application efficiency
- One LED per module
- Mounting holes and pre-mounted adhesive tape allow for easy mounting
- Optimal operation on OPTOTRONIC® 12V power supplies (15W, 30W, 60W, 120W)
- Full encapsulation of the LED modules with ingress protection IP66
- Chain can be subdivided every 3 LED modules
- Fully integrated heat sink

Minimum / Maximum Ratings

Product	Operating Temperature at Tc-Point [°C]*	Storage Temperature [°C]*	Voltage Range [V dc]*	Reverse Voltage [V dc]*
BA01MA-W4F-765	-25 ... 63	-25 ... 55	12 ... 13	13
BA01MA-W4F-830	-25 ... 63	-25 ... 55	12 ... 13	13
BA01MA-R2	-25 ... 63	-25 ... 55	12 ... 13	13
BA01MA-B2	-25 ... 63	-25 ... 55	12 ... 13	13

*) Exceeding maximum ratings for operating and storage temperature will reduce expected life time or destroy the LED Modules.
Exceeding maximum ratings for operating voltage will cause hazardous overload and will likely destroy the LED Modules.
The temperature of the LED modules must be measured at the Tc-point according to EN60598-1 in a thermally constant status with a temperature sensor or a temperature sensitive label.

Dimensions

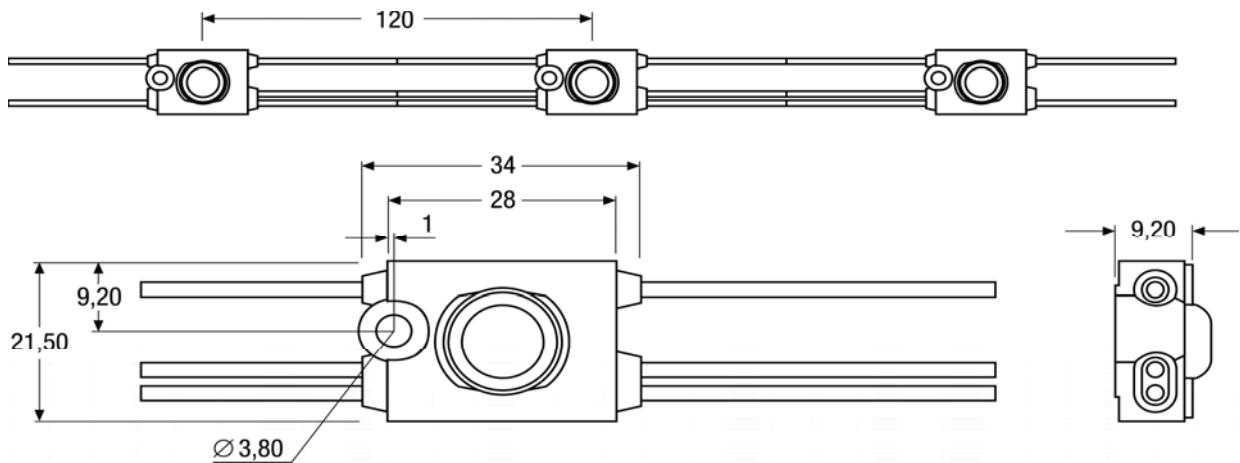

Light Distribution

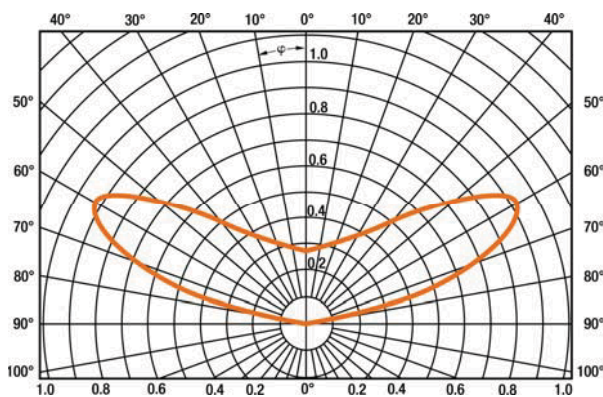

Safety Information

- The LED module itself and all its components must not be mechanically stressed.
- Assembly must not damage or destroy conducting paths on the circuit board.
- To avoid mechanical damage, the LED modules should be attached securely to the intended substrate. Heavy vibration should be avoided.

In order to drive OSRAM LED-Modules safely, it is absolutely necessary to operate them with an electronically stabilized power supply protecting against short circuits, overload and overheating.

To also ease the luminaire/installation approval, electronic control gear for LED or LED modules must carry the CE mark.

In Europe the declarations of conformity must include the following standards:

CE: EC 61347-2-13, EN 55015, IEC 61547 and IEC 61000-3-2 - ENEC: 61347-2-13 and IEC/EN 62384.

Also check for the mark of an independent authorized certification institute.

Please see the relevant brochure for more detailed information (see "Related and Further Information")

OSRAM OPTOTRONIC® electronic control gear complies to all relevant standards and guarantees safe operation.

- Installation of LED modules (with power supplies) needs to be made with regard to all applicable electrical and safety standards. Only qualified personnel should be allowed to perform installations.
- Observe correct polarity!
Incorrect polarity will lead to no light emission. Correct polarity.
- Parallel connection is highly recommended as safe electrical operation mode.
Serial connection is not recommended. Unbalanced voltage drop can cause hazardous overload and damage the LED module.
- Electrical contact is achieved with the contact cables. A maximum 60 modules (20 groups with 3 modules each) can be operated on one OPTOTRONIC® 30W. A maximum of 30 modules (10 groups with 3 modules each) can be operated on one OPTOTRONIC® 15W.
- Installation with more than 60 modules (= one full LED chain) on one OPTOTRONIC® 60W or 120W may take the form with a power feed to the centre or with a splitting of the power feed to contact groups of LED modules.
- Detach the chains only by severing the connecting cables between the modules. Only cut where there are 2 cables leaving the LED board. Not to be cut where 3 cables leave the LED board.
- Pay attention to ESD steps when mounting the module.
- When using power supplies other than OSRAM OPTOTRONIC®, in order to ensure continuous safe operation, the output voltage has to be 12.5V +/- max. 5%.
- The LED module must not be operated in places which are directly exposed to atmospheric conditions. For outdoor applications, hence the LED module has to be protected by appropriate enclosures or covers. Operation in or under water is prohibited.

BackLED L – BA01LA

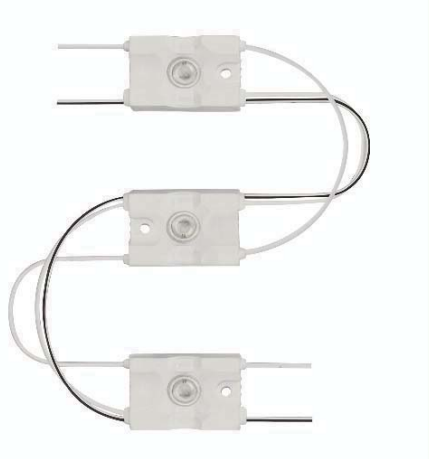

Benefits

- Flexible chain comprising 48 High-Power LED modules
- Specially designed optics provide for uniform backlighting an best-in-class application efficiency

Applications

- Signage and illuminated advertising
- Backlighting of large and deep channel letters

Technical Operating Data

Product	Color	No. of LED-modules per chain	No. of LEDs per module	Voltage [V DC]*	Power chain / module [W]*	Radiance Angle [°]*	Wavelength [nm] Color Temp [K]*	Lum. Flux chain / module [lm]*
BA01LA-W4F-765	White	48	1	12	60.0 / 1.25	155	6500 K	4680 / 97.5
BA01LA-W4F-830	White	48	1	12	60.0 / 1.25	155	3000 K	3600 / 75.0

*) Due to the special conditions of the manufacturing processes of LED the typical data of technical parameters can only reflect statistical figures and do not necessarily correspond to the actual parameters of each single product which could differ from the typical data.

Technical Features

- LED chain comprising 48 LED modules connected by flexible cables
- The maximum length of the entire chain is 9.60m
- The maximum LED pitch is 200mm
- Specially designed optics with Flat-Ray technology for best application efficiency
- One LED per module
- Accessory: BoxLED mounting profile BX-MP for simplified installation in box signs
- Mounting holes and pre-mounted adhesive tape allow for easy mounting
- Optimal operation on OPTOTRONIC® 12V power supplies (15W, 30W, 60W, 120W)
- Full encapsulation of the LED modules with ingress protection IP66
- Chain can be subdivided every 3 LED modules
- Fully integrated heat sink

Minimum / Maximum Ratings

Product	Operating Temperature at Tc-Point [°C]*	Storage Temperature [°C]*	Voltage Range [V dc]*	Reverse Voltage [V dc]*
BA01LA-W4F-765	-25 ... 72	-25 ... 55	12 ... 13	13
BA01LA-W4F-830	-25 ... 72	-25 ... 55	12 ... 13	13

*) Exceeding maximum ratings for operating and storage temperature will reduce expected life time or destroy the LED Modules.
 Exceeding maximum ratings for operating voltage will cause hazardous overload and will likely destroy the LED Modules.
 The temperature of the LED modules must be measured at the Tc-point according to EN60598-1 in a thermally constant status with a temperature sensor or a temperature sensitive label.

Dimensions

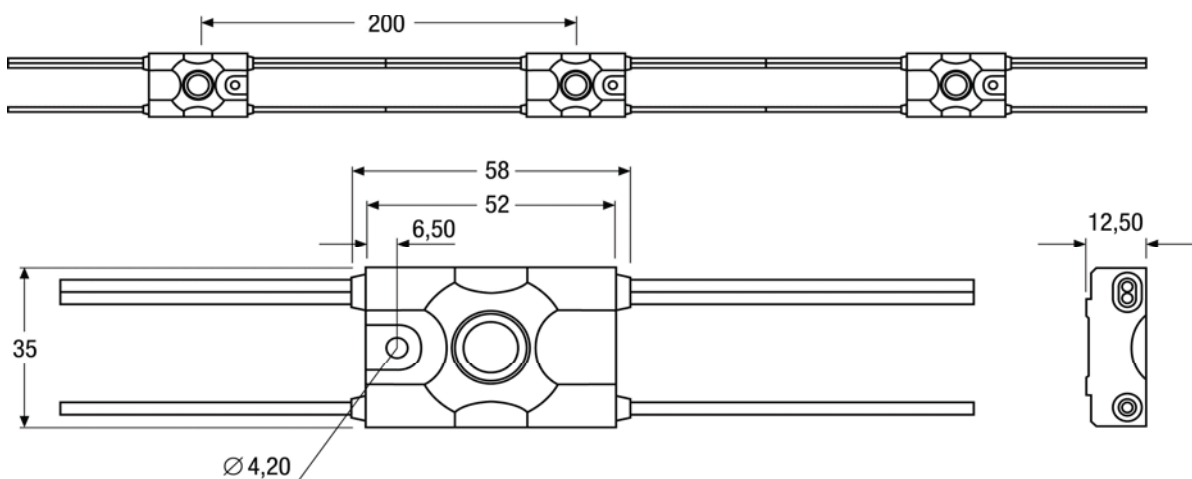

Light Distribution

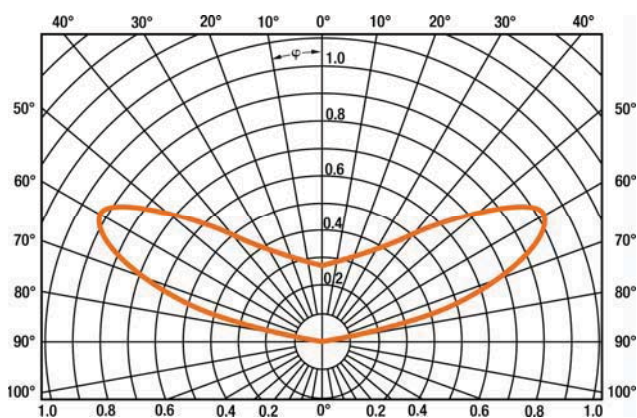

Safety Information

- The LED module itself and all its components must not be mechanically stressed.
- Assembly must not damage or destroy conducting paths on the circuit board.
- To avoid mechanical damage, the LED modules should be attached securely to the intended substrate. Heavy vibration should be avoided.

In order to drive OSRAM LED-Modules safely, it is absolutely necessary to operate them with an electronically stabilized power supply protecting against short circuits, overload and overheating.

To also ease the luminaire/installation approval, electronic control gear for LED or LED modules must carry the CE mark.

In Europe the declarations of conformity must include the following standards:

CE: EC 61347-2-13, EN 55015, IEC 61547 and IEC 61000-3-2 - ENEC: 61347-2-13 and IEC/EN 62384.

Also check for the mark of an independent authorized certification institute.

Please see the relevant brochure for more detailed information (see "Related and Further Information")

OSRAM OPTOTRONIC® electronic control gear complies to all relevant standards and guarantees safe operation.

- Installation of LED modules (with power supplies) needs to be made with regard to all applicable electrical and safety standards. Only qualified personnel should be allowed to perform installations.
- Observe correct polarity!
Incorrect polarity will lead to no light emission. Correct polarity.
- Parallel connection is highly recommended as safe electrical operation mode.
Serial connection is not recommended. Unbalanced voltage drop can cause hazardous overload and damage the LED module.
- Electrical contact is achieved with the contact cables. A maximum 48 modules (16 groups with 3 modules each) can be operated on one OPTOTRONIC® 60W. A maximum of 24 modules (8 groups with 3 modules each) can be operated on one OPTOTRONIC® 30W. A maximum of 12 modules (4 groups with 3 modules each) can be operated on one OPTOTRONIC® 15W.
- Installation with more than 48 LED modules (= one full chain) on one OPTOTRONIC® 120W may take the form with a power feed to the centre or with a splitting of the power feed to contact groups of single LED modules
- Detach the chains only by severing the connecting cables between the modules. Only cut where there are 2 cables leaving the module. Not to be cut where 3 cables leave the module.
- Pay attention to ESD steps when mounting the module.
- When using power supplies other than OSRAM OPTOTRONIC®, in order to ensure continuous safe operation, the output voltage has to be 12.5V +/- max. 5%.
- The LED module must not be operated in places which are directly exposed to atmospheric conditions. For outdoor applications, hence the LED module has to be protected by appropriate enclosures or covers. Operation in or under water is prohibited.

BoxLED Back – BX03BA



Benefits

- Linear LED Modules connected by flexible cables
- Specially designed optics provide for uniform backlighting and best-in-class application efficiency

Applications

- Signage and illuminated advertising
- Backlighting of single- and double-sided box signs (backlight)

Technical Operating Data

Product	Color	No. of LED-modules per chain	No. of LEDs per module	Voltage [V DC]*	Power chain / module [W]*	Radiance Angle [°]*	Wavelength [nm] Color Temp [K]*	Lum. Flux chain / module [lm]*
BX03BA-W4F-765	White	16	3	12	60.0 / 3.75	155	6500 K	4680 / 292.5

*) Due to the special conditions of the manufacturing processes of LED the typical data of technical parameters can only reflect statistical figures and do not necessarily correspond to the actual parameters of each single product which could differ from the typical data.

Technical Features

- LED chain comprising 16 modules connected by flexible cables
- The maximum length of the entire chain is 9.60m
- The maximum LED pitch is 110mm
- Specially designed optics with Flat-Ray technology for best application efficiency
- Three LEDs per module
- Accessory: BoxLED mounting profile BX-MP for simplified installation
- Mounting holes and pre-mounted adhesive tape allow for easy mounting
- Optimal operation on OPTOTRONIC® 12V power supplies (15W, 30W, 60W, 120W)
- Full encapsulation of the LED modules with ingress protection IP66
- Fully integrated heat sink
- Simple and universal mounting with BoxLED mounting profile (accessory)

Minimum / Maximum Ratings

Product	Operating Temperature at Tc-Point [°C]*	Storage Temperature [°C]*	Voltage Range [V dc]*	Reverse Voltage [V dc]*
BX03BA-W4F-765	-25 ... 72	-25 ... 55	12 ... 13	13

*) Exceeding maximum ratings for operating and storage temperature will reduce expected life time or destroy the LED Module.
Exceeding maximum ratings for operating voltage will cause hazardous overload and will likely destroy the LED Module.
The temperature of the LED module must be measured at the Tc-point according to EN60598-1 in a thermally constant status with a temperature sensor or a temperature sensitive label.

Dimensions

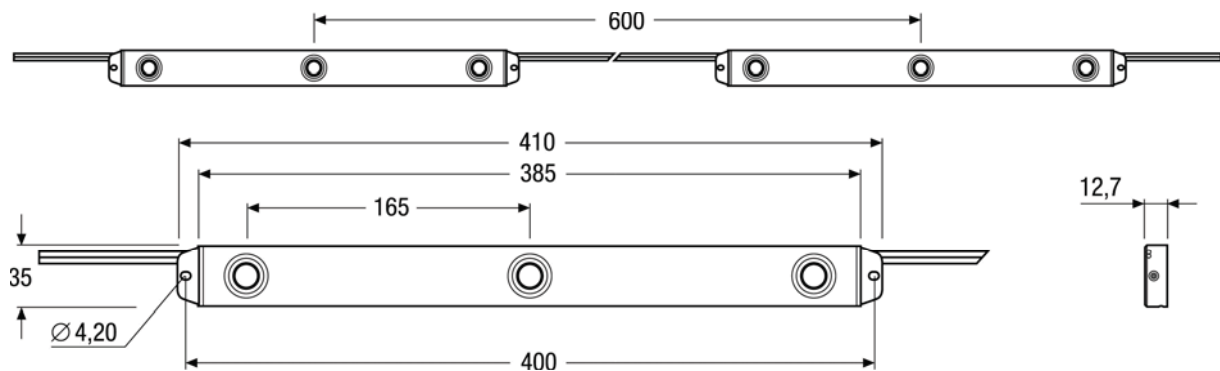

Light Distribution

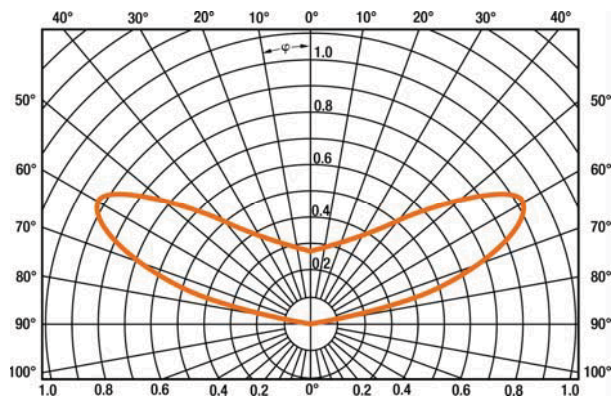

Safety Information

- The LED module itself and all its components must not be mechanically stressed.
- Assembly must not damage or destroy conducting paths on the circuit board.
- To avoid mechanical damage, the LED modules should be attached securely to the intended substrate. Heavy vibration should be avoided.

In order to drive OSRAM LED-Modules safely, it is absolutely necessary to operate them with an electronically stabilized power supply protecting against short circuits, overload and overheating.

To also ease the luminaire/installation approval, electronic control gear for LED or LED modules must carry the CE mark.

In Europe the declarations of conformity must include the following standards:

CE: EC 61347-2-13, EN 55015, IEC 61547 and IEC 61000-3-2 - ENEC: 61347-2-13 and IEC/EN 62384.

Also check for the mark of an independent authorized certification institute.

Please see the relevant brochure for more detailed information (see "Related and Further Information")

OSRAM OPTOTRONIC® electronic control gear complies to all relevant standards and guarantees safe operation.

- Installation of LED modules (with power supplies) needs to be made with regard to all applicable electrical and safety standards. Only qualified personnel should be allowed to perform installations.
- Observe correct polarity!
Incorrect polarity will lead to no light emission. Correct polarity.
- Parallel connection is highly recommended as safe electrical operation mode.
Serial connection is not recommended. Unbalanced voltage drop can cause hazardous overload and damage the LED module.
- Electrical contact is achieved with the contact cables. A maximum 16 modules can be operated on one OPTOTRONIC® 60W. A maximum of 8 modules can be operated on one OPTOTRONIC® 30W. A maximum of 4 modules can be operated on one OPTOTRONIC® 15W.
- Installation with more than 16 modules (= one full LED chain) on one OPTOTRONIC® 120W may take the form with a power feed to the centre or with a splitting of the power feed to contact groups of LED modules.
- Detach the chains only by severing the connecting cables between the modules.
- Pay attention to ESD steps when mounting the module.
- When using power supplies other than OSRAM OPTOTRONIC®, in order to ensure continuous safe operation, the output voltage has to be 12.5V +/- max. 5%.
- The LED module must not be operated in places which are directly exposed to atmospheric conditions. For outdoor applications, hence the LED module has to be protected by appropriate enclosures or covers. Operation in or under water is prohibited.

BoxLED Side – BX03SA



Benefits

- Linear LED Modules connected by flexible cables
- Specially designed optics provide for uniform backlighting and best-in-class application efficiency

Applications

- Signage and illuminated advertising
- Backlighting of single- and double-sided box signs (side-lighting)

Technical Operating Data

Product	Color	No. of LED-modules per chain	No. of LEDs per module	Voltage [V DC]*	Power chain / module [W]*	Radiance Angle [°]*	Wavelength [nm] Color Temp [K]*	Lum. Flux chain / module [lm]*
BX03SA-W4F-765	White	8	3	12	60.0 / 7.5	12x65	6500 K	3932 / 491.5

*) Due to the special conditions of the manufacturing processes of LED the typical data of technical parameters can only reflect statistical figures and do not necessarily correspond to the actual parameters of each single product which could differ from the typical data.

Technical Features

- LED chain comprising 8 LED modules connected by flexible cables
- The maximum length of the entire chain is 3.60m
- The maximum LED pitch is 110mm
- Specially designed optics with elliptical radiation pattern
- Three LEDs per module
- Accessory: BoxLED mounting profile BX-MP for simplified installation in box signs
- Mounting holes and pre-mounted adhesive tape allow for easy mounting
- Optimal operation on OPTOTRONIC® 12V power supplies (15W, 30W, 60W, 120W)
- Full encapsulation of the LED modules with ingress protection IP66
- Fully integrated heat sink
- Simple and universal mounting with BoxLED mounting profile (accessory)

Minimum / Maximum Ratings

Product	Operating Temperature at Tc-Point [°C]*	Storage Temperature [°C]*	Voltage Range [V dc]*	Reverse Voltage [V dc]*
BX03SA-W4F-765	-25 ... 88	-25 ... 55	12 ... 13	13

*) Exceeding maximum ratings for operating and storage temperature will reduce expected life time or destroy the LED Module.
 Exceeding maximum ratings for operating voltage will cause hazardous overload and will likely destroy the LED Module.
 The temperature of the LED module must be measured at the Tc-point according to EN60598-1 in a thermally constant status with a temperature sensor or a temperature sensitive label. For exact location of the Tc-point see drawing below.

Dimensions

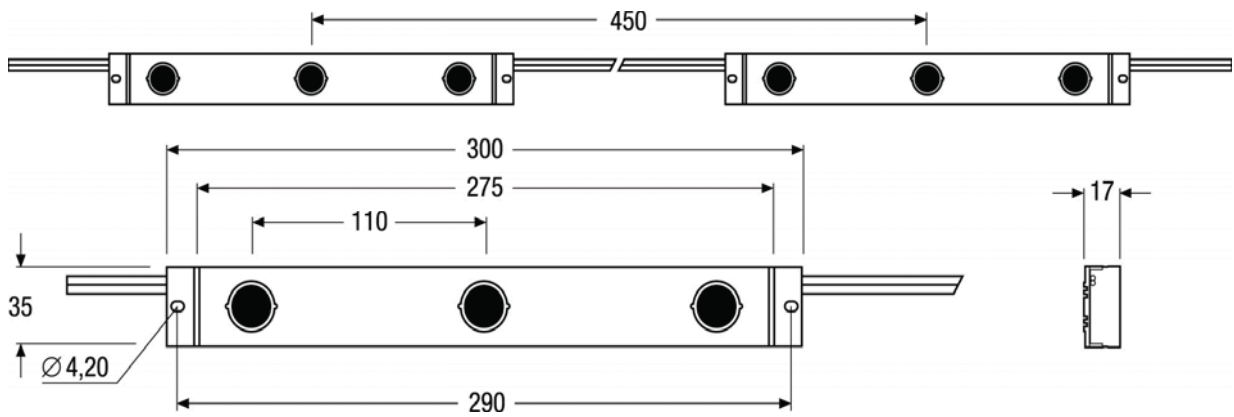

Light Distribution

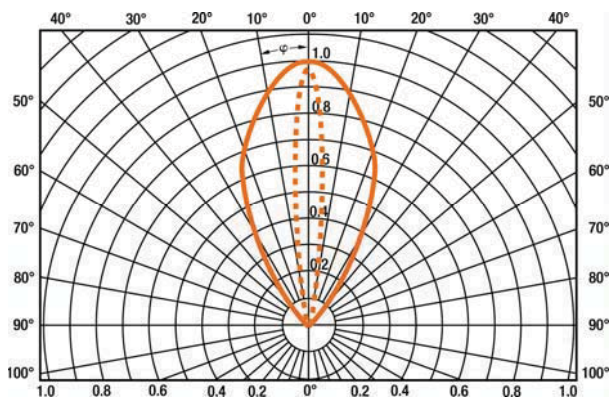

Safety Information

- The LED module itself and all its components must not be mechanically stressed.
- Assembly must not damage or destroy conducting paths on the circuit board.
- To avoid mechanical damage, the LED modules should be attached securely to the intended substrate. Heavy vibration should be avoided.

In order to drive OSRAM LED-Modules safely, it is absolutely necessary to operate them with an electronically stabilized power supply protecting against short circuits, overload and overheating.

To also ease the luminaire/installation approval, electronic control gear for LED or LED modules must carry the CE mark.

In Europe the declarations of conformity must include the following standards:

CE: EC 61347-2-13, EN 55015, IEC 61547 and IEC 61000-3-2 - ENEC: 61347-2-13 and IEC/EN 62384.

Also check for the mark of an independent authorized certification institute.

Please see the relevant brochure for more detailed information (see "Related and Further Information")

OSRAM OPTOTRONIC® electronic control gear complies to all relevant standards and guarantees safe operation.

- Installation of LED modules (with power supplies) needs to be made with regard to all applicable electrical and safety standards. Only qualified personnel should be allowed to perform installations.
- Observe correct polarity!
Incorrect polarity will lead to no light emission. Correct polarity.
- Parallel connection is highly recommended as safe electrical operation mode.
Serial connection is not recommended. Unbalanced voltage drop can cause hazardous overload and damage the LED module.
- Electrical contact is achieved with the contact cables. A maximum 8 modules can be operated on one OPTOTRONIC® 60W. A maximum of 4 modules can be operated on one OPTOTRONIC® 30W. A maximum of 2 modules can be operated on one OPTOTRONIC® 15W.
- Installation with more than 8 modules (= one full LED chain) on one OPTOTRONIC® 120W may take the form with a power feed to the centre or with a splitting of the power feed to contact groups of LED modules.
- Detach the chains only by severing the connecting cables between the modules.
- Pay attention to ESD steps when mounting the module.
- When using power supplies other than OSRAM OPTOTRONIC®, in order to ensure continuous safe operation, the output voltage has to be 12.5V +/- max. 5%.
- The LED module must not be operated in places which are directly exposed to atmospheric conditions. For outdoor applications, hence the LED module has to be protected by appropriate enclosures or covers. Operation in or under water is prohibited.

Alimentatori



QUICKTRONIC PROFESSIONAL QT-FIT8 Versione monolampada	PREZZO	
QTP-DL 1X18-24 omologato per lamp. 15 W	€ 20,40	preriscaldamento
QTP5 1X24-39 omologato per lamp. 30 W	€ 17,40	preriscaldamento
QT-FIT8 1X36	€ 14,55	preriscaldamento
QT-FIT8 1X58-70	€ 14,55	preriscaldamento

QUICKTRONIC PROFESSIONAL QT-FIT8 Versione bilampada	PREZZO	
QTP-DL 2X18-24 omologato per lamp. 15 W	€ 22,50	preriscaldamento
QT-FIT8 2X18	€ 15,60	preriscaldamento
QTP5 2X24-39 omologato per lamp. 30 W	€ 20,40	preriscaldamento
QT-FIT8 2X36	€ 15,60	preriscaldamento
QT-FIT8 2X58-70	€ 15,60	preriscaldamento

QUICKTRONIC PROFESSIONAL QTP5 Versione monolampada	PREZZO	
QTP5 1X1435	€ 17,40	

QUICKTRONIC PROFESSIONAL QTP5 Versione bilampada	PREZZO	
QTP5 2X1435	€ 20,40	